

**HOBART****VPU400  
FOOD PROCESSOR****HOBART****STANDARD FEATURES**

- Gear transmission.
- Anodized aluminum housing.
- Two-speed motor.
- Triple hopper/cover interlock.
- Two stationary front legs and two rear legs with casters for ease of mobility.
- Processes up to 90 lbs. per minute.
- Plates interchangeable with FP350.

**ACCESSORIES**

- 3- pack plates ( $\frac{1}{16}$ " ,  $\frac{5}{32}$ " slicer plates,  $\frac{3}{16}$ " shredder plate and wall rack).
- 6-pack plates (same as 3-pack plus  $\frac{3}{8}$ " ,  $\frac{7}{32}$ " slicer plates,  $\frac{3}{8}$ " dicer plate and additional wall rack).
- 3-peg wall rack (designed to hold 3 plates).
- Stainless steel accessory cart.
- Adjustable height stainless steel lug cart.
- Stainless steel pan.
- Plastic pan.
- 41 individual plates available.

**MODEL**

- FP400-1 (Must also select Feed Hopper Choice)

**FEED HOPPER CHOICES**

- Manual/Tubular Cylinder (PFD-CYL)
  - Choose one or both:
    - Manual Push Feed Assembly.
    - Tubular Feeder.
- Bulk Feed Hopper and Cylinder (Complete).

Specifications, Details and Dimensions on Reverse Side.

**FP400 FOOD PROCESSOR**

# VPU-400 FOOD PROCESSOR

# HOBART

**SPECIFICATION:** 2 H.P. two speed motor, 250/500 rpm, anodized case aluminum housing. Plates are interchangeable with FP350 and are constructed of stainless steel blades with aluminum frames.

**ELECTRICAL SPECIFICATIONS:** 208-240/60/3, 7.5 amps, 6 foot, 3 conductor power cord (16 AWG). Furnished with NEMA L15-20P locking type plug.

**WEIGHT:** Net Lbs.: Machine 119 lb., Feed Cylinder 13 lb., Manual Push Feeder 11 lb., Continuous Feed Hopper 27 lb.

## DETAILS AND DIMENSIONS

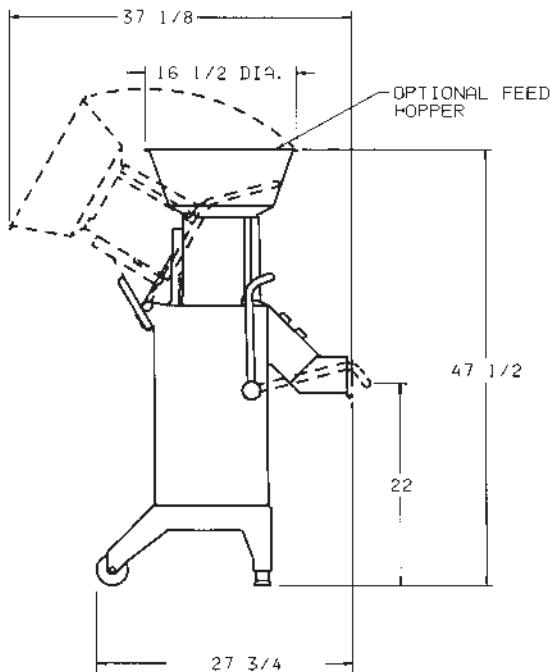
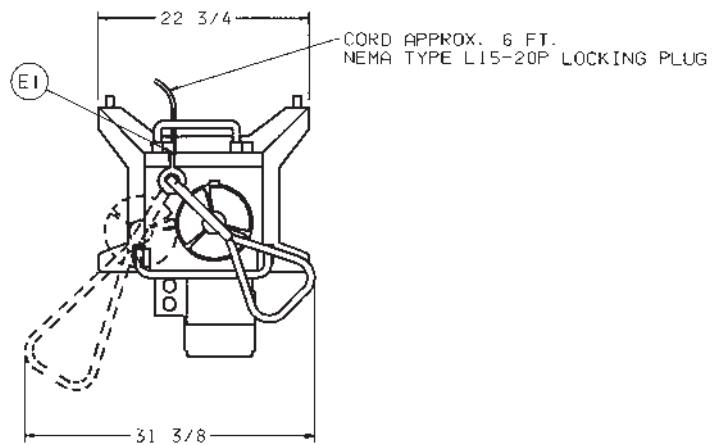
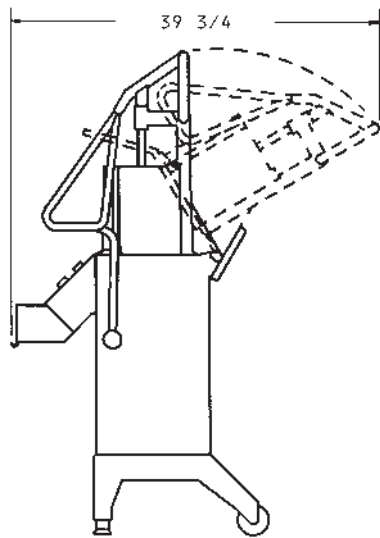

OPTIONAL MANUAL  
PUSH HEAD

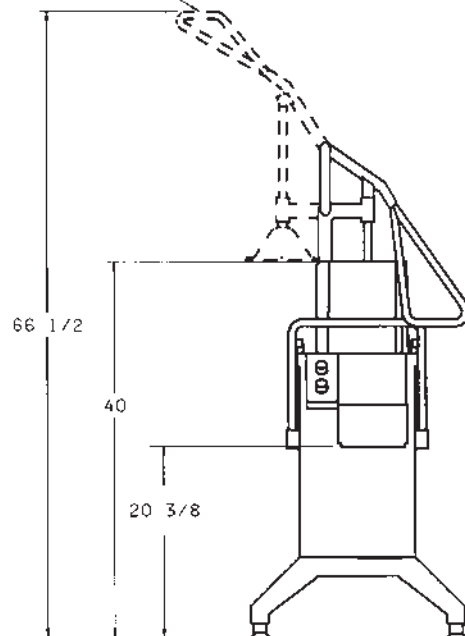

As continued product improvement is a policy of Hobart, specifications are subject to change without notice.